



# HYDRAULIC HOSE CRIMPER

DISTRIBUTORS  
MANUFACTURERS  
REPAIR SHOPS...  
PRODUCE PRECISE  
IN-HOUSE HOSE  
ASSEMBLIES USING  
ANY BRAND OF FITTING

## **PULSAR**

# 20





**1**

Select proper hose and fitting and push coupling onto hose.

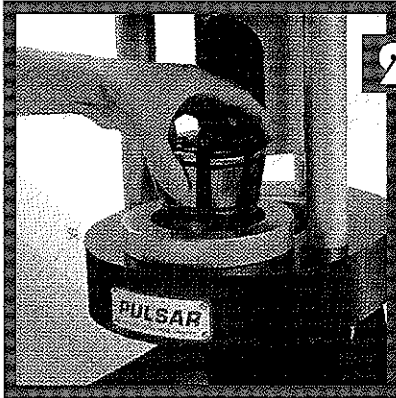

**2**

Select appropriate die set from crimp chart.

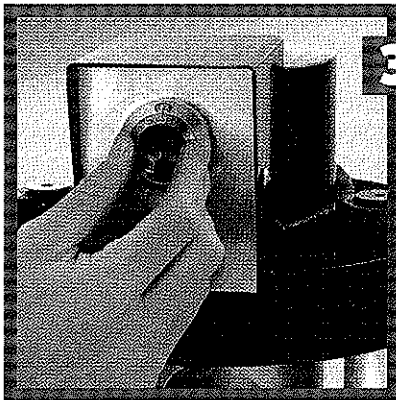

**3**

Set dial micrometer to proper setting.

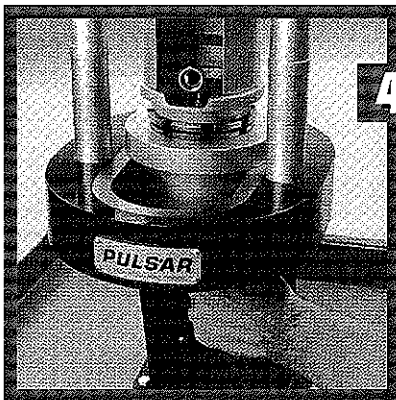

**4**

Position hose and coupling in die set.

## HOW TO USE THE PULSAR 20 CRIMP SYSTEM

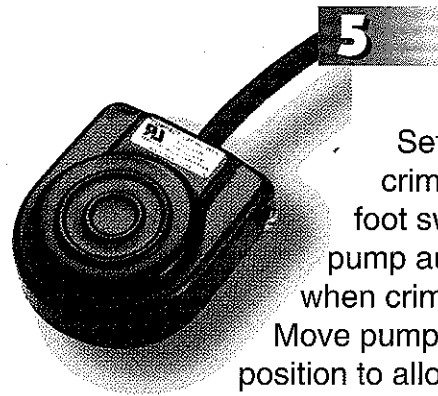

**5**

Set pump handle to crimp position. Press the foot switch, dies close and pump automatically stops when crimp cycle is complete. Move pump handle to return position to allow dies to open.

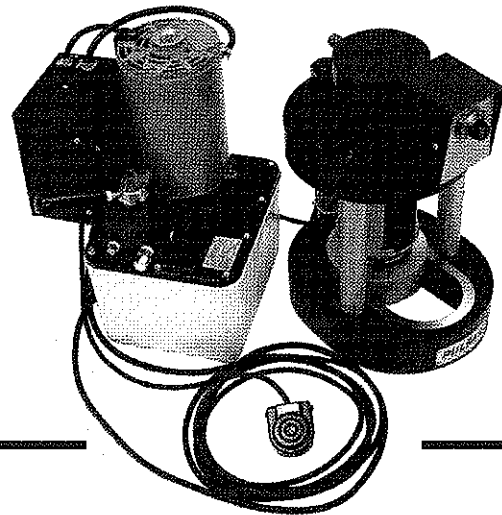

# PULSAR 20

DISTRIBUTED BY:

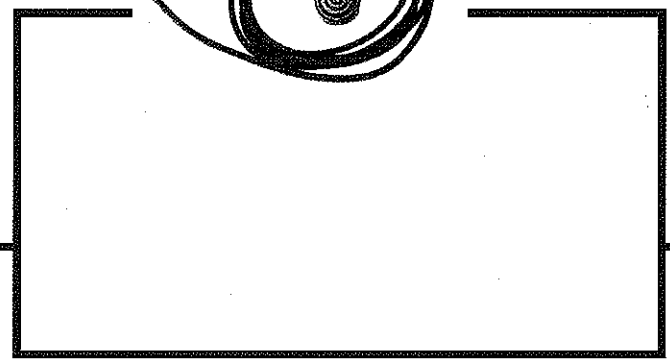

## **PULSAR 20**

### **INSTALLATION INSTRUCTIONS**

1. Attach crimper stand to a 1-1/2" thick workbench with the (6) 3/8" bolts and washers supplied. NOTE: The workbench should be secured to the floor or a wall to prevent it from tipping over.
2. Place the crimper on the stand, lifting it with the eye-bolts supplied. Secure the press to the stand with the (4) 3/8" cap-screws also supplied.
3. Place hydraulic power supply on the bench to the left of the crimper with the hydraulic port on the right.
4. Connect crimper cylinder to the 90' female JIC long elbow on the hydraulic hose and connect the 45' female JIC end to the pump.
5. Connect the female two-prong electrical plug from the pump to the male two-prong plug from the crimper.
6. Lightly lubricate all unpainted surfaces of the die shoe and baseplate with grease.
- 7.
8. Plug in the power supply to a 115 volt/15 amp/60 Hz outlet. NOTE: Do not use additional extension cord or operate additional equipment off the designated crimper outlet.
9. Place die holder in the base plate.
10. Oil level should be 1" below the top of the reservoir.
11. Should additional oil be necessary use 20 weight hydraulic oil, (ISO 46 or equivalent.)

## PULSAR 20

### OPERATING INSTRUCTIONS

1. Select the appropriate hose and cut to length.
2. Select the appropriate crimp ferrule and slide over the hose. Push the proper crimp insert into the hose until it bottoms. This will be easier if both the stem and hose are lubricated with a compatible oil.
3. Select the appropriate die set number, pusher-ring, and dial setting.
4. Slide the die holder out from under the pusher.
5. Insert the hose assembly in from the bottom. Place the die set over the coupling.
6. Place pusher-ring over the coupling so that it is flush on the center of the die set.
7. While holding the assembly, slide the die shoe fully back to position the die set under the pusher, (this activates the safety switch and allows the crimper to run.)
8. Adjust the height and alignment of the assembly within the die set to obtain proper coupling placements, (so that elbow fittings clear the pusher-ring and that the dies will crimp the ferrule correctly.)
9. Set lever on pump to ADVANCE position. Depress footswitch to crimp. Crimper will stop at predesignated dial setting and crimp diameter.
10. Set lever on pump to RETRACT position and the crimper will automatically retract to start position.
11. Check crimp diameter with a digital or dial type caliper.

# PULSAR 20

## CALIBRATION PROCEDURES

NOTE: All *PULSAR 20* crimpers are calibrated at the factory

1. Remove black dial cover by removing the two holding screws and sliding the cover upward.
2. Turn dial counter-clockwise until it stops. At this time, the microswitch should be at the top of the lead screw.
3. Locate the Allen head set screw on the knob at #75 on the dial face. Loosen the Allen screw with a .050 Allen wrench, (supplied.)
4. Hold the gears with your finger and the dial base with your thumb, and turn the dial face until you reach #1495. Then carefully re-tighten the Allen set screw.

## TROUBLE SHOOTING

### 1. CRIMPER DOES NOT ACTIVATE:

<u>Possible Cause</u>	<u>Corrective Action</u>
a. Breaker switch	a. Check breaker box and reset.
b. Low voltage	b. Check for use of extension cord.
c. Safety switch not activated	c. Insure die holder is fully back against crimper base.

### 2. INCORRECT CRIMP DIAMETER:

<u>Possible Cause</u>	<u>Corrective Action</u>
a. Using wrong die set	a. Check die set selection for hose and fitting used.
b. Incorrect dial setting	b. Review crimp chart and adjust dial setting.
c. Crimper improperly calibrated	c. Check calibration instructions and re-calibrate.
d. Lack of grease	d. Lubricate die shoe and dies with grease.

**IMPORTANT. DISCONNECT POWER SUPPLY !!!**

- (1). Dismantle new switch assemble by removing 2 bolts and nuts (A) and hex bolts (B).
- (2). Remove two red connectors.
- (3). Remove cover from existing switch. Unbolt assy and remove from crimper.
- (4). Cut wires from existing terminals, strip and crimp black wires using new red connectors.

If necessary cut back outer cover of cable to provide more slack.

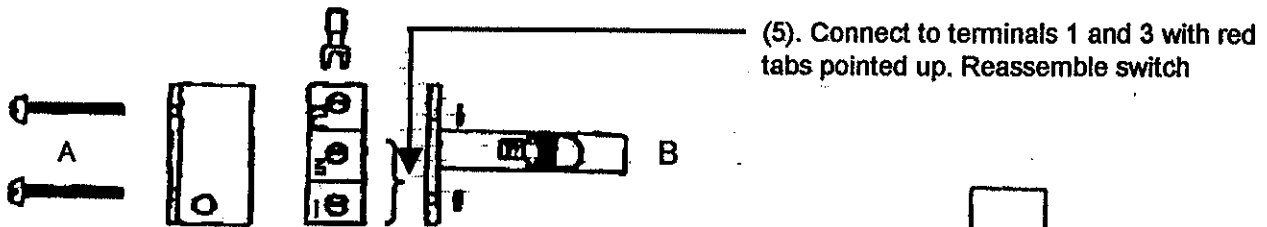

(5). Connect to terminals 1 and 3 with red tabs pointed up. Reassemble switch

- (6). Mount switch on rear support column by attaching collar with hex bolts (B)
- (7). Provide proper clearance by setting switch assy with 1/8" gap from top of baseplate.
- (8). Secure cable to switch assy with wire tie provided.

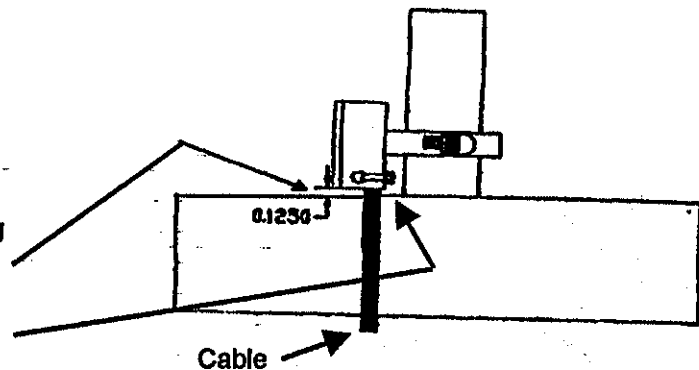

(9). Final Adjustment.  
Place die shoe in base plate and slide back firmly to operating position.  
Rotate switch until it clicks closed and tighten collar screws to lock in position.

(10). Reconnect power supply and test unit by sliding die shoe forward. Unit should NOT work.

(11). Slide shoe to operating position, pump should start.

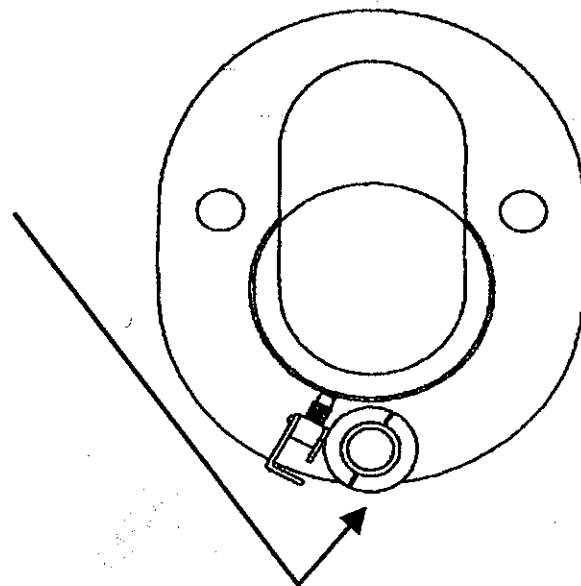

**NEVER OPERATE MACHINE**  
**IF SWITCH IS NOT FUNCTIONING**